

 Applies To: **See VEHICLES AFFECTED**
April 23, 2004

Safety Recall: Automatic Transmission Second Gear Inspection

BACKGROUND

Certain operating conditions can result in heat buildup between the countershaft and secondary shaft second gears in the automatic transmission. Without enough oil flow to dissipate heat, prolonged operation under these conditions can eventually result in decreased material strength. In higher mileage vehicles, this can result in gear tooth chipping or, in very rare cases, gear breakage.

In most cases, transmission noise will indicate a problem, however it is possible for the transmission to become locked without warning. A locked transmission could result in a crash.

VEHICLES AFFECTED

2002–03 Odyssey: ALL

2004 Odyssey: From VIN 5FNRL18..4B000001 thru
5FNRL18..4B051620

2003 Pilot: ALL

2004 Pilot: From VIN 2HKYF18..4H500001 thru
2HKYF18..4H546877

CUSTOMER NOTIFICATION

All owners of affected vehicles will be sent a notification of this recall.

Not all vehicles within the VIN ranges are affected by this recall. Before beginning work on a vehicle, verify its eligibility by checking at least one of these items:

- The customer has a notification letter.
- The vehicle is shown on your campaign responsibility report.
- The vehicle is shown as eligible on an iN VIN status inquiry.

In addition to these verification items, check for a punch mark above the 11th character of the engine compartment VIN. A punch mark in that location means the A/T has already been inspected and repaired.

Some vehicles affected by this recall may be in your new or used vehicle inventory. **According to federal law, these vehicles cannot be sold or leased until they are repaired.** To see if a vehicle is affected by this recall, do a VIN status inquiry before selling it.

CORRECTIVE ACTION

Vehicles with 15,000 miles or less:

Install an A/T oil jet kit.

Vehicles with *more than* 15,000 miles:

Do a photographic, *not visual*, inspection of the A/T second gear:

- Using the digital camera and camera mount in the A/T Gear Inspection Kit, take five clear photos of the second gear through the countershaft speed sensor hole.
- Load the photos onto an iN workstation, then display them on the monitor.
- Compare the gear color in the photos with the gear colors in the A/T Gear Inspection Guide that came with the camera.
- If you determine that the color of the gear in your photos matches gear level number 1 on the inspection guide, install an A/T Oil Jet Kit.
- If you determine that the color of the gear in your photos matches any gear level other than number 1 on the inspection guide, submit a completed A/T order form, with your digital photographs, to RPO Tech Line. RPO will either cancel your A/T order and let you know you need to install an A/T Oil Jet Kit, or process your A/T order so you can install a remanufactured A/T.

PARTS INFORMATION

A/T Oil Jet Kit:

P/N 06250-PGH-305, H/C 7758931

(Contains oil jet, oil jet line with bracket, ATF hose, ATF filler plug adapter, sealing washer, two O-rings, and three hose clamps)

This draft expires on 4/29/04. A final version will be available on 4/30/04.

TOOL INFORMATION

A/T Gear Inspection Kit:

The kit contains these items:

- Canon Powershot A75 digital camera:
P/N CNUA75
(with Digital Camera Solution Disk Ver. 17.1 software, USB interface cable, four AA batteries, Compact Flash card, user guide, and quick start guide)
- Camera mount with bracket and spacer:
P/N 07AAB-PGHA100, H/C 7754286
- Two *Streamlight* flexible “white LED” flashlights:
P/N STL65618
- Color bar stickers:
P/N 07AAB-PGHA200
- Numbering stamp (commercially available)
- Ink pad (commercially available)
- A/T Gear Inspection Guide:
Helm reorder number Y0680
This guide contains photos of the A/T second gear in conditions varying from *good* to *not good*. Use the guide to help you decide the condition of the gear. The gear color determines whether or not a replacement transmission is needed. If you need more inspection guides, order them through Helm.

WARRANTY CLAIM INFORMATION

OP#	Description	FRT	Template ID
222106	Vehicles with 15,000 miles or less: Install A/T oil jet kit	0.8	04-021A
222107	Vehicles with more than 15,000 miles: Inspect A/T; install A/T oil jet kit	1.2	04-021B
222108	Odysseys with more than 15,000 miles: Inspect A/T; install remanufactured A/T	7.8	Use a Regular Claim format
222108	Pilots with more than 15,000 miles: Inspect A/T; install remanufactured A/T	8.3	Use a Regular Claim format

Failed Part: P/N 23441-P7W-000
H/C 6274872

Defect Code: 5CS

Symptom Code: P30

Skill Level: Repair Technician

INSPECTION PROCEDURE

NOTE:

- If you are viewing this service bulletin on ISIS, you can [CLICK HERE](#) for an animated view of the inspection and repair procedures.
 - If you're working on a vehicle with 15,000 miles or less, go directly to **REPAIR PROCEDURE**.
 - For questions on camera adjustment, camera mounting, or gear condition, call RPO Tech Line at (888) 997-7278, and select option #2. **Do not** call automobile Tech Line.
 - For questions on camera warranty and camera software, call American Honda Special Tools at (800) 346-6327.
1. Remove the intake manifold cover and the intake air duct. *For Odyssey*, refer to the 1999–04 Odyssey Service Manual, pages 5-2 and 5-3. *For Pilot*, refer to the 2003–04 Pilot Service Manual, page 5-2.
 2. Clean the area around the ATF filler bolt, the countershaft speed sensor, and the ATF filter lines.

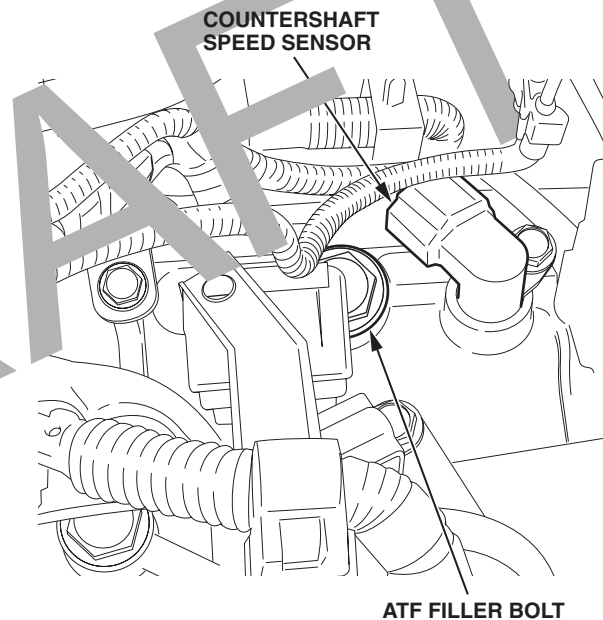

3. Remove the countershaft speed sensor. *For Odyssey*, refer to the 1999–04 Odyssey Service Manual, page 14-134. *For Pilot*, refer to the 2003–04 Pilot Service Manual, page 14-123.

This draft expires on 4/29/04. A final version will be available on 4/30/04.

This draft expires on 4/29/04. A final version will be available on 4/30/04.

4. Connect an air nozzle to the shop air supply. Insert the air nozzle into the countershaft speed sensor hole, and apply air to the top of the second gear for at least 15 seconds.

NOTE: This step is very important; it removes residual ATF from the second gear so you can see it more clearly. Do not use anything but compressed air for this step.

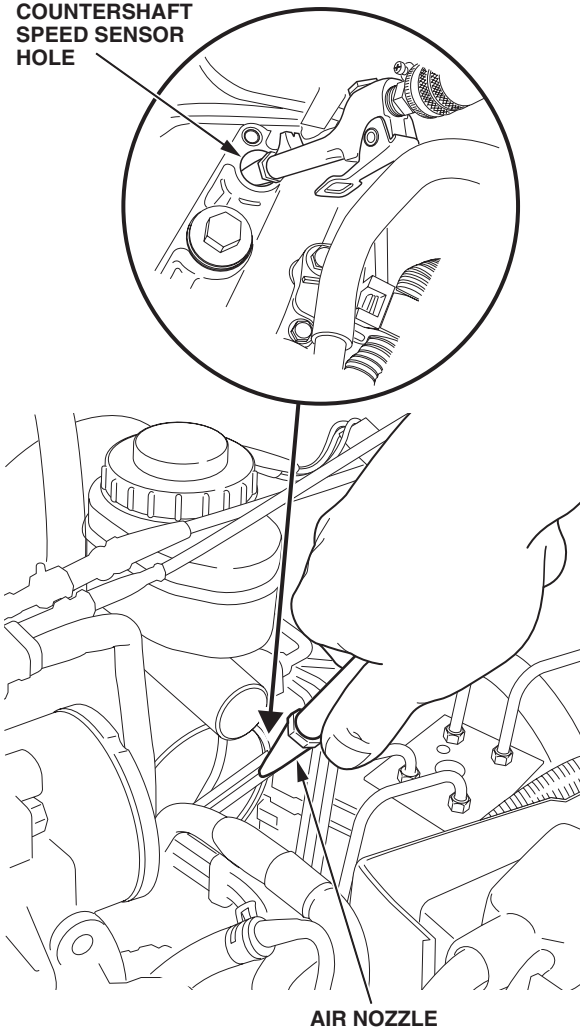

5. Using a clean shop towel, wipe out the bore of the countershaft speed sensor hole.

6. Shine the LED flashlight into the speed sensor hole. Using a small, flat-tip screwdriver, scrape across the top of the gear teeth. This will help you get a clearer photo of the gear.

NOTE:

- If the gear teeth are brighter where you scraped them, it's an initial indication of gear overheating.
- The angle cuts near the top of the gear teeth are not a defect in the gear; they are used to identify gears during transmission assembly.

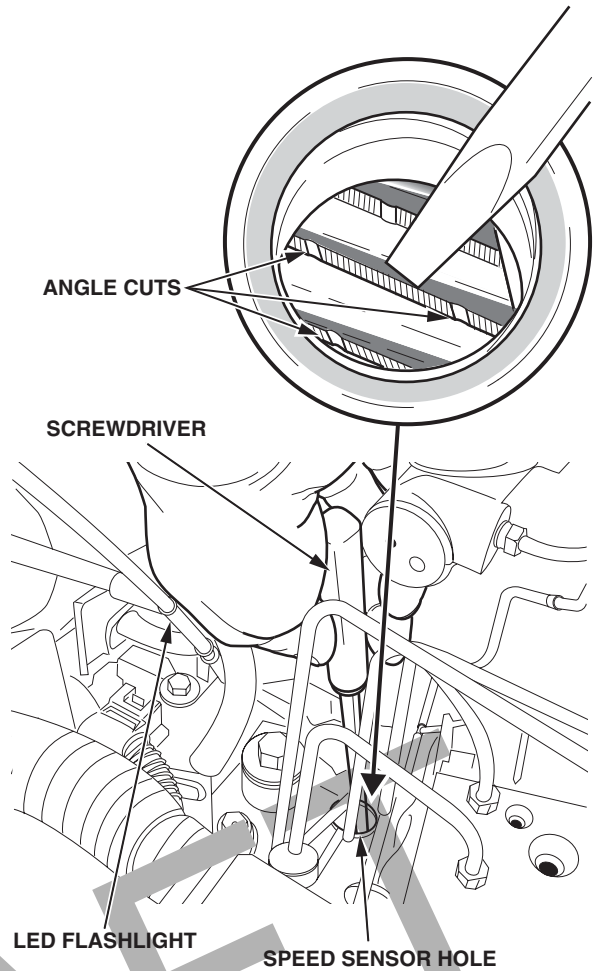

DRAFT

7. Prepare the digital camera for use, and adjust its settings. Most settings are saved after the initial adjustment. Refer to the *Powershot A75 Digital Camera User Guide* and the *Powershot A75 Digital Camera Quick Start Guide* as needed.

- Open the battery door on the bottom of the camera, and install the four AA batteries.
- Open the CF door on the side of the camera, then insert the CF card.
- Turn on the camera, and select Manual mode by rotating the dial on the top of the camera to **M**.
- Turn on the flash by pressing the **▲** button on the back of the camera.
- Press the **FUNC.** button on the back of the camera, and adjust these mode settings in the Function menu:
 - In the Flash mode, select a flash output of **2/3rds** (nine green dashes), then press the down arrow.
 - In the White Balance mode, select **Cloudy**, then press the down arrow.
 - In the Drive mode, select the **rectangle**, then press the down arrow.
 - Adjust the ISO speed to **50**, then press the down arrow.
 - Select **Effect Off**, then press the down arrow.
 - Select **Center Weighted Avg.**, then press the down arrow.
 - Select **L** resolution (2048 x 1536), then press the **SET** button.
 - Select **Superfine** compression, then press the **FUNC.** button.
 - Adjust the shutter speed to **1/200**, then press the **SET** button.
 - Adjust the aperture to **F8.0**, then press the **MENU** button.
- Adjust these mode settings in the Rec. Menu:
 - In the AiAF mode, select **On**, then press the down arrow.
 - In the Red-eye mode, select **Off**, then press the down arrow.
 - In the AF-assist Beam mode, select **On**, then press the down arrow.
 - In the Digital Zoom mode, select **On**, then press the down arrow.
 - Adjust the Review to **5 sec.** Press the down arrow, then press the forward arrow.

- Adjust these mode settings in the Setup menu:
 - In the Mute mode, select **Off**.
 - In the Volume mode, press the forward arrow, then select full volume in all areas (Start-up, Operation, Self-timer, Shutter, and Playback). Press the **MENU** button, press the down arrow, then press the forward arrow.
 - In the Auto Power Down mode, select **Off**. Then press the **MENU** button, and press the down arrow.
 - Set the year, month, day, and time, then press the down arrow twice. (This bypasses the Format mode, which should *not* be adjusted.)
 - In the File No. Reset mode, select **Off**, then press the down arrow.
 - In the Auto Rotate mode, select **Off**, then press the down arrow.
 - In the Distance Units mode, select **ft/in**. Then press the down arrow, and press the forward arrow.
 - In the Language mode, select **English**, then press the **MENU** button, and press the down arrow.
 - In the Video System mode, select **NTSC**, then press the **Menu** button. (The My Camera menu does not need adjustment.)
- **Every time you turn on the camera, check or adjust these settings:**
 - Make sure the flash is on.
 - Select Manual mode by rotating the dial on the top of the camera to **M**.
 - Turn on the Macro by pressing the down arrow once. (The flower icon appears in the lower right corner of the display.)
 - Set the zoom to 6.0x: Move the zoom lever to the right, hold it for about 3 seconds, then release it; toggle the lever three times to the right until 6.0x appears in the display.

This draft expires on 4/29/04. A final version will be available on 4/30/04.

8. Stick a color bar sticker on the base of the camera mount. Using the number stamp and ink pad, dial in the last six digits of the VIN, ink the stamp, and then stamp the VIN onto the color bar sticker.

NOTE: For verification purposes, you'll need to use a new color bar sticker and the correct last six digits of the VIN for each vehicle inspected.

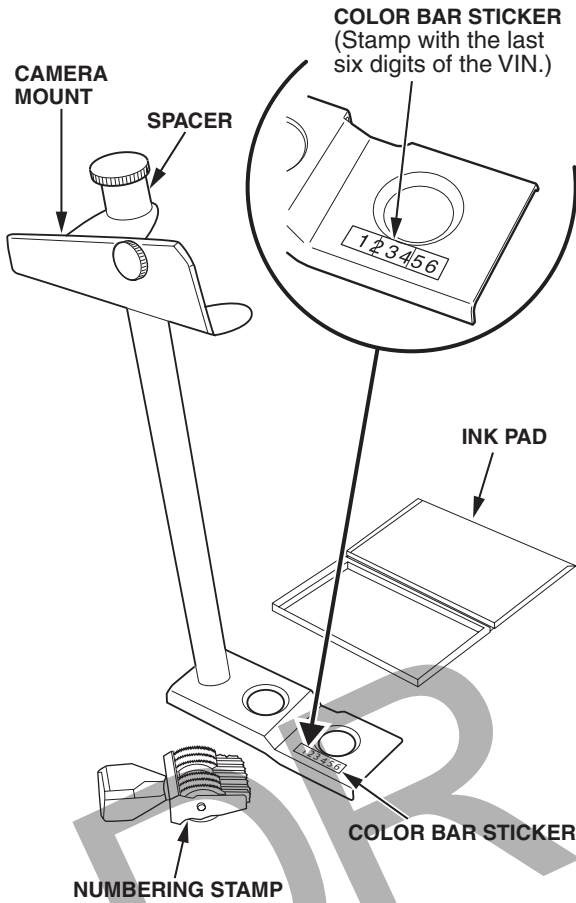

9. Remove the ATF filler bolt.
10. On an Odyssey, remove the junction connector from the bracket.

11. Use the ATF filler bolt to attach the camera mount to the transmission.

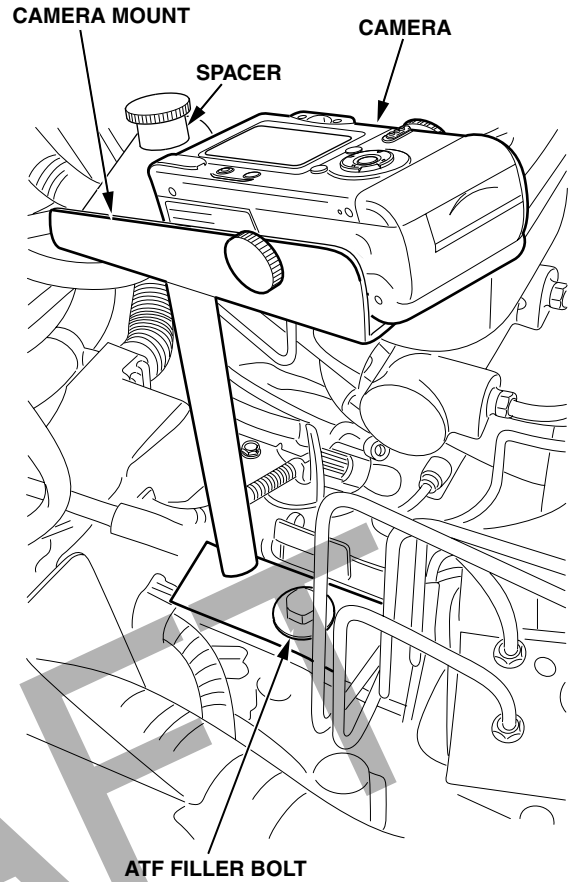

12. Attach the camera to the camera mount. Make sure the camera spacer is correctly installed, and be careful not to damage the plastic threads in the bottom of the camera.
13. Turn on the camera. Select Manual mode (M), turn on the macro (the flower icon appears in the lower right corner of the display), and set the digital zoom to 6.0x. Make sure the flash is on.
14. Line up the rectangle in the camera display to the center of the gear inside the speed sensor hole. (The picture in the display will not look as good as the actual photo.)
15. Shine the flexible LED flashlight inside the hole. This helps the camera focus on the gear. You will turn the flashlight off before taking the photo.
16. Push the camera shutter button half way down, and hold it. The rectangle in the camera display turns green to show that the camera is in focus. If the rectangle doesn't turn green, release the shutter button, then hold it half way down again. Repeat this until the rectangle turns green.
17. Turn off the flashlight, and remove it from the area. Press the shutter button all the way down.
18. Repeat steps 14 thru 17 to take five clear photos of the gear. If needed, reposition the camera mount to center your photos.

19. Remove the camera from the camera mount.
20. Remove the camera mount from the transmission.
21. Reinstall the countershaft speed sensor, tighten the sensor bolt to 12 N·m (8.7 lb-ft), and reconnect the sensor connector.
22. Select Play mode by sliding the switch on the back of the camera to ▶ . Then turn off the camera.
23. Load the camera software (Digital Solutions Disk V17.1) onto your iN workstation. For loading instructions, refer to the *Powershot A75 Quick Start Guide*, step 6.
24. Attach the USB interface cable to a **USB** port on the back of the iN workstation and to the **Digital** terminal on the left side of the camera.
25. Turn on the camera.

NOTE: The rest of the photo downloading steps are done on the iN workstation, not the camera.

26. When the “Camera Window Download Images” screen appears on the iN display, click on **List Images**.
27. Click on the images you want to download to the iN workstation.
28. Click on **Download Image**. The Download Setting menu appears.
29. Click on **Select New Folder**. Name the new folder the 17-digit VIN you’re currently working on. Click on **OK**.
30. To view a photo, double-click on it. Delete any photos you do not intend to use.
31. Using the *Automatic Transmission Gear Inspection Guide* (reorder #Y0680), match the color of the gear in your photos with one of the gear condition levels on the guide. For a good match of gear color, it’s helpful to hold the inspection guide next to the monitor. It’s also good to get a consensus of the gear color with at least one other person.

NOTE: The color of the gear in your photos should be similar to the photos in the inspection guide. If your photos are not similar, try viewing them on a different monitor.

- If you determine that the color of the gear in your photos matches gear level #1 on the inspection guide, install an oil jet kit. Go to step 3 of **REPAIR PROCEDURE**.
- If you determine that the color of the gear in your photos matches any gear condition level other than #1 on the inspection guide, send your photos to RPO Tech Line for review. Go to step 32.

32. Bring up the Warranty Automatic Transmission Order form on the iN:

NOTE: For additional information on filling out the order form and uploading images to the iN see the Job Aid, *Quick Start Warranty A/T Order Images*, on ISIS.

- From the iN main menu, click on **Service**.
- From the Service drop down menu, click on **Warranty A/T Order**.
- Enter the model and year of the vehicle, then click on **Search**.
- At the top of the screen, click on **Warranty Automatic Transmission Order**.

33. Fill out all required fields on the Warranty Automatic Transmission Order form. (Required fields have a red dot next to them.)

34. In the order form’s Service Bulletin 04-021 field, click on **Yes**.

35. Click on **Image Upload**, and browse for the VIN file you are going to upload. Preview the photo if needed by double-clicking on it. If the photo is not clear, select another one. Do this step for each photo you are submitting.

NOTE: Uploading must be done one photo at a time.

36. Click on **Submit** to send the A/T order form and the photos to RPO Tech Line. RPO will review the photos and determine if the transmission needs an oil jet kit or if it needs to be replaced.

- If the gear color is normal, your transmission order will be canceled, and RPO will let you know you need to install an oil jet kit. To install an oil jet kit, go to step 3 of **REPAIR PROCEDURE**.
- If the gear color indicates an overheating condition, your transmission order will be processed, and the replacement transmission will be sent as soon as possible. When you receive the replacement transmission, go to step 22 of **REPAIR PROCEDURE**.

This draft expires on 4/29/04. A final version will be available on 4/30/04.

This draft expires on 4/29/04. A final version will be available on 4/30/04.

REPAIR PROCEDURE

1. Remove the intake manifold cover and the intake air duct. *On Odysseys*, refer to the 1999-04 Odyssey Service Manual, pages 5-2 and 5-3. *On Pilots*, refer to the 2003-04 Pilot Service Manual, page 5-2.
2. Clean the top of the transmission around the ATF filler bolt, the countershaft speed sensor, and the ATF filter lines.

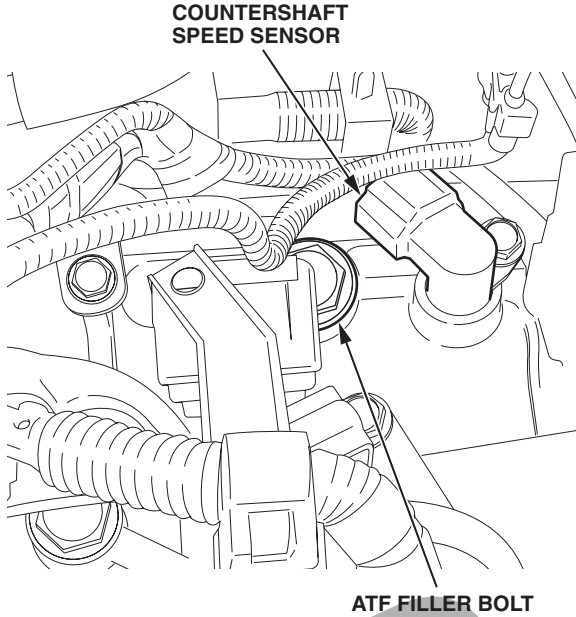

3. For better access to the ATF filter line assembly *on Pilots*, unbolt the ABS modulator from its mounting bracket, and move the modulator up slightly. For better access to the ATF filter line assembly *on Odysseys*, disconnect the ABS modulator connector, and move the connector out of the way.

4. Disconnect the ATF hose from the ATF filter line, and discard the hose clamp.

A/T BEFORE INSTALLATION OF A/T OIL JET KIT

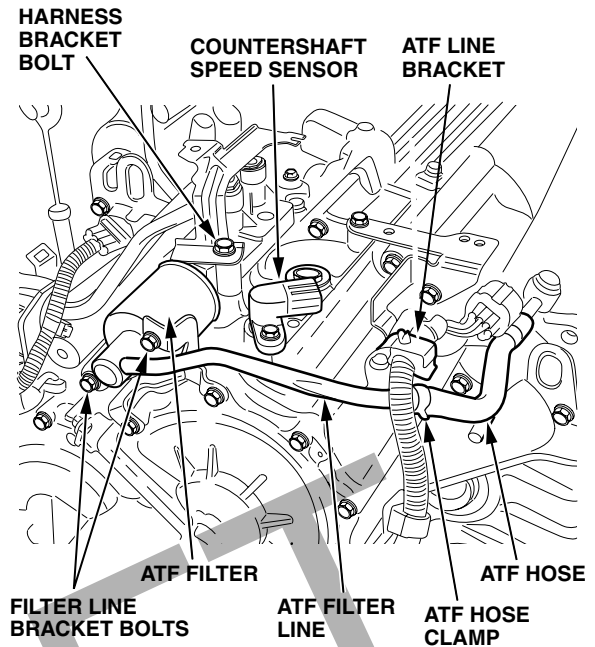

5. Detach the wire harness from the ATF line bracket.
6. Remove the filter line bracket bolts, then remove and discard the ATF filter line assembly.

7. Assemble the A/T Oil Jet Kit.

NOTE:

- Make sure there are no kinks in the oil jet hose when you install it on the transmission. Also make sure you install the oil jet hose to the base of the "T" on the oil jet line.
- Each hose clamp has a retainer to hold it in its spread position. To install a hose clamp, slide it into position (7 mm from the end of the hose), then pull off the retainer with pliers.
- Use clean ATF to lubricate the oil jet O-ring and the ATF filter O-ring before installation.

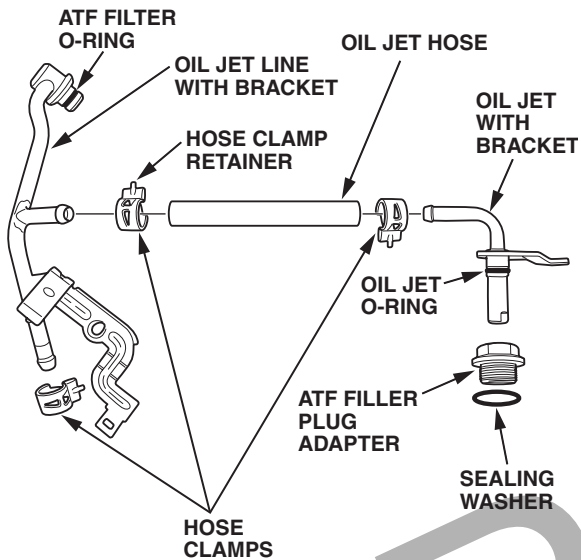

8. Install the oil jet line on the ATF hose with a new hose clamp.

A/T AFTER INSTALLATION OF A/T OIL JET KIT

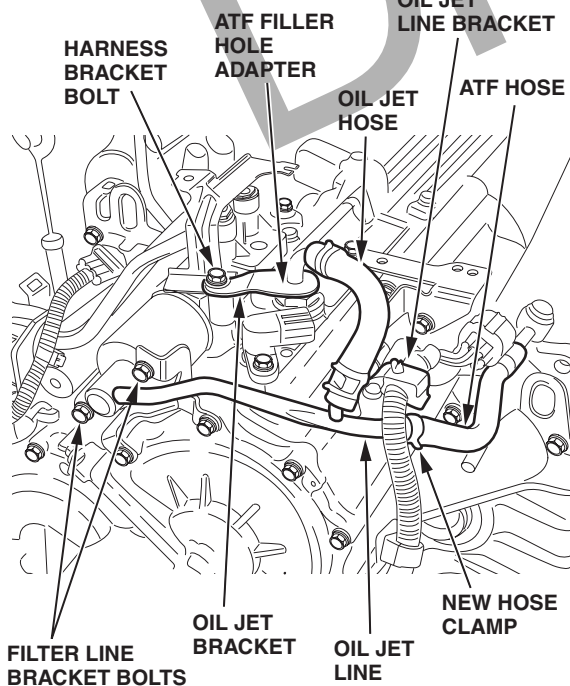

9. Install the other end of the oil jet line on the ATF filter, and tighten the filter line bracket bolts to 12 N·m (8.7 lb-ft).
10. Remove the harness bracket bolt.
11. Remove and discard the ATF filler bolt.
12. Install the ATF filler plug adapter with a new sealing washer, and torque the adapter to 44 N·m (33 lb-ft).
13. Insert the oil jet into the filler plug adapter, and make sure the oil jet is flush. Position the oil jet bracket over the harness bracket bolt hole. Reinstall the harness bracket bolt, and torque it to 27 N·m (20 lb-ft).
14. Attach the oil jet line bracket, and torque the bolt to 12 N·m (8.7 lb-ft).
15. Connect the wire harness connector, and attach the harness to the oil jet line bracket.
16. Clean up any residual ATF that spilled when you installed the oil jet kit.
17. On Pilots, Reinstall the ABS modulator. On Odysseys, reconnect the ABS modulator connector.
18. Start the engine. Move the shift lever to Drive, and then to Reverse. Move the shift lever to Drive and then to Park. Raise the idle speed to 1,500 rpm, keep it there for several minutes, then turn off the engine.
19. Check for ATF leaks at the oil jet kit. If you find any leaks, make sure the filler plug adapter, the oil jet, and all hose clamps are correctly installed.
20. Check the ATF level, and add fluid if needed.
21. Reinstall the intake air duct and the intake manifold cover, **then go to step 23.**
22. Replace the transmission. *For Odyssey, refer to the 1999-04 Odyssey Service Manual, pages 14-138 thru 14-154. For Pilot, refer to the 2003-04 Pilot Service Manual, pages 14-133 thru 14-153. On ISIS, use the keywords "trans removal" and "trans install."*

NOTE:

- Replacement transmissions do not require an A/T Oil Jet Kit.
- When refilling the transmission, use Honda Genuine Transmission Fluid ATF-Z1.
- Follow all instructions in the service manual, including the engine idle learn procedure and the road test.
- After the road test, recheck the ATF level, add fluid if needed, and check for leaks.

23. Center-punch a completion mark above the 11th character of the engine compartment VIN.

Center-punch here.

2HGRL1XXXXXXXXXX

This draft expires on 4/29/04. A final version will be available on 4/30/04.

April 23, 2004

Dear Service Manager:

Honda Motor Co., LTD has announced a safety recall campaign for certain 2002–04 Odysseys and 2003–04 Pilots.

Certain operating conditions can result in heat build-up between the countershaft and secondary shaft second gears in the automatic transmission. Without enough oil flow to dissipate heat, prolonged operation under these conditions can eventually result in decreased material strength. In higher mileage vehicles, this can result in gear tooth chipping or, in very rare cases, gear breakage.

In most cases, transmission noise will indicate a problem, however it is possible for the transmission to become locked without warning. A locked transmission could result in a crash.

Affected Vehicles

All 2002–03 Odysseys and 2003 Pilots are affected by this campaign. Also included are some early-production 2004 Odysseys and Pilots. (For the 2004 VINs, refer to Service Bulletin 04-021, *Safety Recall: Automatic Transmission Second Gear Inspection*.) **According to Federal law, any new or used affected vehicle in your vehicle inventory cannot be sold or leased until it is repaired.**

Repair Strategy

On vehicles with less than 15,000 miles, install an A/T Oil Jet Kit (no inspection needed). The oil jet kit sends a supply of ATF directly to the second gears, preventing heat build-up.

For all other vehicles, inspect the second gear through the countershaft speed sensor hole, and take five clear photos of the gear using the camera and equipment in the supplied A/T Gear Inspection Kit. Then view the photos on your iN workstation, and compare them to the gear color levels in the supplied A/T Gear Inspection Guide.

- If you determine that the color of the gear in your photos matches gear level #1 on the A/T Gear Inspection Guide, install an A/T Oil Jet Kit.
- If you determine the color of the gear in your photos matches any gear level other than number 1 on the A/T Gear Inspection Guide, submit a completed A/T order form, with your digital photographs, to RPO Tech Line. RPO will either cancel your A/T order and let you know you need to install an A/T Oil Jet Kit, or process your A/T order so you can install a remanufactured A/T.

For inspection, repair, ordering, and warranty information, refer to Service Bulletin 04-021, *Safety Recall: Automatic Transmission Second Gear Inspection*. Today, a draft of service bulletin 04-021 is available on ISIS. A final version of the service bulletin will be available on April 30.

Tool Information

An A/T Gear Inspection Kit was sent to each dealer on April 21. The kit contains a digital camera, a camera mount, a laminated A/T Gear Inspection Guide, and everything else you need to take photos of the second gear.

Parts Information

Today, we are sending you enough oil jet kits to repair your in-stock vehicles and to handle critical case customers. A larger allocation of oil jet kits will be sent on April 29.

Customer Notification

Notifications will be mailed to all owners over a period of time, starting with the owners of the oldest vehicles first. Mailings begin around May 12. As soon as possible, we will let you know, via the iN, the specific mail dates.

Please direct any rental car requests to your DPSM.

Sincerely,

**American Honda Motor Co., Inc.
Honda Automobile Division**